



# “READY ROOM”

## NEWSLETTER

Volume 7 : Issue 2

*Our Mission is to increase the public's awareness of aviation through the flight of historical aircraft, while supporting our local children's hospital.*

## Anonymous Donation Received

An anonymous supporter donated a beautiful plaque dedicated to Charles Augustus Lindbergh the American aviator. The plaque showcases photos of Lindbergh with goggles and helmet ready for flight, posing with his monoplane, The Spirit of St. Lewis, and a full body picture of the plane, which Lindbergh used on the first solo flight from New York to Paris, France. The plaque looks stunning in the ready room.



From left to right: Brad Robert, Chip Hood, Matt DeVille, and Christine Lewis.

## The C-45 Receives Some TLC

The members were busy joining forces to paint and prime the C-45 to get it in tip-top shape. Easier said than done with an aircraft of its size. Thank you to everyone that came out and put in some elbow grease.



# DeFuniak Springs Marvel of Flight Airshow

The DeFuniak Springs Marvel of Flight Airshow was the perfect event to welcome in April. All of the hard work that so many people put into the C-45 finally paid off as it took to the sky for the first time in three years. Other highlights of the airshow include the C-45 and the T-28 flying in formation together, static displays of our aircraft and other expos & flights by; the Tiger Flight Foundation, the Flying Musicians Foundation, and the Army Aviation Heritage Foundation. Thank you to everyone that came out to help the museum and play with the planes.



From left to right: Nick, JD, Matt DeVille, Todd, and Peter O'Hare pose with their futuristic comrades in front of the T-28.



Todd Verno showcases his culinary skills after a long day at the airshow.



Pattie Wagstaff with Jay DeVille.

# Wings Over Golden Isles Airshow

The museum had a great weekend from March 24-26. The Wings Over Golden Isles Airshow in Brunswick, Georgia was a big event, but because of everyone that came out to help, the museum was well represented. The public enjoyed tours, activities for the kids, and our static displays. The 55,000 attendees that came out to enjoy the beauty of aviation were also able to see demonstrations by the US Navy Blue Angels, AeroShell Acrobatic Team, the US Air Force F 22 Raptor, and so much more. The Smoke-n-Thunder Concert Series in the evening included acts by the Ladies of Liberty & Sky Soldiers and the band .38 Special. The weekend was a great opportunity for the museum to advertise our mission statement and everything that we do in our community.



Matt, Jason, Shawn, Tony, and Trevor Neal wow fans.



Peter O'Hare leads a static aircraft tour.



**423-227-2972**

# Toppers Roofing & Home Improvement



We have a great way for you to get work done on your house and donate to the Museum of Flight!

*Toppers Home Improvements in business since 2004*

**Will donate 50% of the profits from  
any roofing or large home  
improvement project to the museum**

Give us a call today **423-227-2972** and use the **Code word T28** to get your home fixed up and donate to the museum at the same time!

Commercial and Residential, Chattanooga, Atlanta, Knoxville,  
Nashville, Birmingham, Rome and all points in between

# Open House

The open house on Saturday, March 11<sup>th</sup> was an extraordinary success. The public enjoyed museum tours, a wide array of activities, special exhibits, and food. Attendees were lucky enough to enjoy a chance to enjoy a wide variety of aircraft. Mark Brereton and Ron Dobbs were generous enough to give away rides in their aircraft, Mark Brereton offered rides in his helicopter and Ron Dobbs flew his 500, to those that donated to the museum. The public also had the ability to take a flight in the giant, ancient beast that is the T-28B. Other exhibits and activities included; military vehicles ordinance display, Tiger Flight rides, a thrust versus torque demonstration, C-45 engine start and taxi, and Vietnam re-enactors.

Elizabeth Davis and Doug Woodruff spent the day emceeing, giving narration to the various events. This was an excellent opportunity for the museum to engage with the public and show them what we can do, and how they can take part. A big thank you goes to everyone that came out to show their support and help the event run smoothly.



Mark Brereton and Ron Dobbs generously offered flights in their helicopters.



The Home Depot children's station was a hit.



Rosie The Riveters are all smiles at their booth.



Lucas Lackey, gets some one-on-one time with the shoulder mount rocket launcher.

Photo by: Doug Walker, Northwest Georgia News



Vietnam reenactors under the museums captured an Iraqis soviet 152 Howitzer that would have been used by the NVA.



Open house guest speaker Sam Spector.



(Doug Walker RN-T)

# AH-1S Cobra Joins Flight Museum Collection

In 2004, John Woodward, from our partner flying museum Army Aviation Heritage Foundation (AAHF), visited Fort Drum, NY to select fourteen Cobras to move down to Atlanta. In Atlanta, six of them would be restored to flyable condition to fulfill a contract with Army Recruiting Command to become the Army's official air show team. The other eight machines would be stashed in a back hangar as parts replacement sources, or to be made flyable in the future. All fourteen aircraft were selected because they either flew into Fort Drum when they were dropped off, or they had exceptional component life (hours) left.



Pete O'Hare sought a way to bring an airframe, not selected for the air show demonstration team, into more public view and upon relocation of the museum to the Rome hangar, asked AAHF if one could be acquired on loan. That was a capital idea, as the terms of the Army's original loan program specified that they be made available to be seen by the general public to the greatest extent possible.

Plans were put in motion to move an AH-1S Cobra helicopter from Hampton, GA to Rome, GA. It was not a swift process, as paperwork needed to be submitted to the Army agency that controls where attack helicopters can be placed on loan. There was back-and-forthing of paperwork between AAHF and the Army, then AAHF and our Flight Museum. Christine Lewis made a trip to Hampton to check out the situation (and bring back the Huey tailboom we have) and a conversation she had with AAHF President Ed Clark during the 2016 Rome Air Show cleared the last administrative hurdle.

To get us across the finish line, member Tony Neal stepped up to be the AH-1 Project Manager. He investigated many combinations of dates and conveyances available to move a forty-eight foot long, low-slung helicopter. Not just any flatbed would do, so Tony sought out a low-boy of a certain configuration. This turned into a Goldilocks story. Some trailers were too big, some were too small. He finally found the man who had one that was "just right." That man is Greg Landry.



Greg asked for dimensional drawings and data on tie-down points in order to ensure the helicopter would ride snug and secure, while still clearing the low-boy's wheel well. He put in many hours figuring out the best way to accomplish the mission and his solution is so elegant it is now THE textbook answer on how to move a helicopter of this configuration.

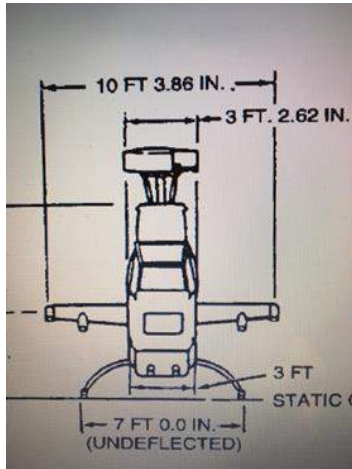



When the rig pulled up to the hangar in Rome on 18 March, Development Director Matthew DeVille and a number of member volunteers were on hand to receive the bird. DeVille had coordinated with Lee Bagley of Prestige Builders to use a crane to gently offload the aircraft.





As it sits on our hangar deck, AH-1S Serial number 70-15942, is capable of being returned to service as a flyable airworthy aircraft. It has FAA registration number N942HF. When you visit, you will see that "some assembly required" applies at present. It will be a work in progress to restore this Cobra so that it can proudly represent the Army's use of the type over the years from Vietnam (when the turret was fitted with a 40mm grenade launcher and 7.62 minigun that spit out 4,000 rounds per minute) through Desert Storm (when the anti-tank TOW missile was employed alongside 2.75" rockets under the wing stub).

Pictures by Tony Neal

DeHart

25 March 2017

## A Big Thanks to Lee Bagley

Lee Bagley of Prestige Builders and Maloney's Tree Service generously donated his crane to be used to offload the AH-1S Cobra helicopter during its recent move to the museum. Because of Bagley's generosity the move went off without a hitch.





## 2015/2016 SCHEDULE OF EVENTS

<u>DATE</u>	<u>EVENT</u>	<u>LOCATION</u>	<u>STATUS</u>
March 11	Open House	Rome Airport	Complete
March 24-26	Airshow	Brunswick	Complete
March 31-April 1	Airshow	DeFuniak Springs	Complete
April 8-9	Airshow	Columbus	Complete
April 15	Open Hangar Gala	Rome Airport	
June 10	Airshow	PDK Good Neighbor	
September 23	Airshow	Lafayette, GA	
September 30	Airshow	Crossville, TN	
October 20-22	Airshow	Coosa Valley Fairground	

## LIFETIME MEMBERS

Jeanne & Tony Bass  
Shawn Barber  
Voron Baughon  
Jim Beaver  
Ernie Betancourt  
Dr. Gary Caldwell  
Phil Cataldo  
Dr. Donald Chamberlain  
Nan Coddington  
Ronnie Cox  
Dr. James Creel  
Erich DeHart  
Vance Engle

Logan DeHart  
Peyton Dehart  
Ron Dobbs  
Scott Ducker  
Phil Gilliland  
International Aviation Services  
Larry Jarrett  
Chris Keefe  
David Lawson  
Christine Lewis  
Frank Kalinowski  
Art Matthews  
Spencer Morgan

Scott Murray  
Pete and Susan O'Hare  
Scott Pilkington Sr.  
Sol Snyder  
Don Shephard  
John Sullivan  
Stratton Tingle  
Wayne Vick  
Brent Wade  
David Wells  
Jody Whitmire  
Ed Woods  
Jorge Verdias

Judy Wilson  
Doug Woodruff  
Kim Watkins  
James Green  
Fred Amicangioli  
Capt. Don Bailey